

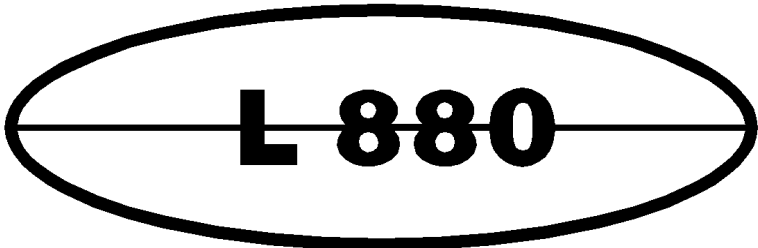

TECHNICAL INFORMATION

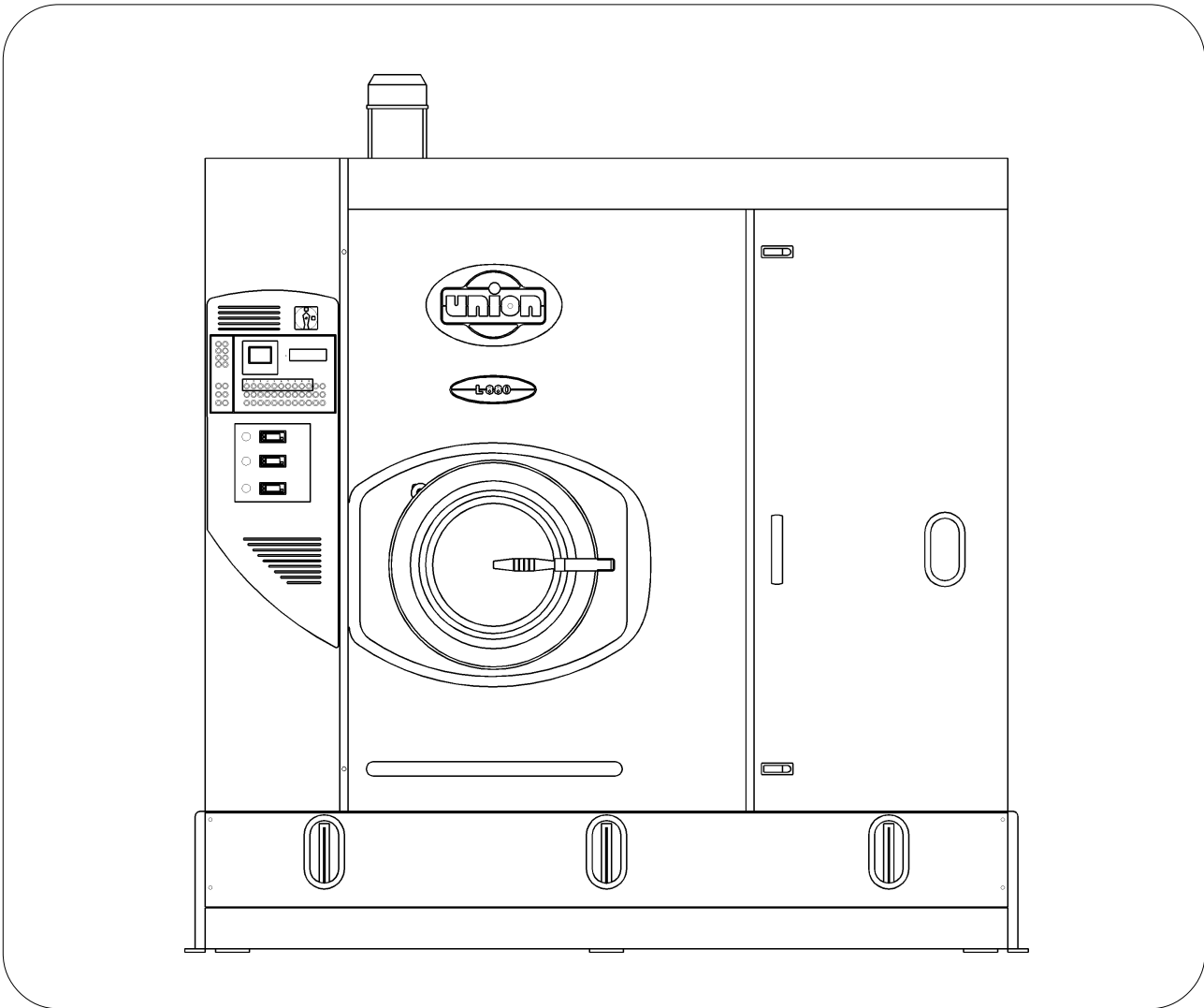



WORKING MACHINE WITH SOLVENT	PERCHLORETHYLENE	
MACHINE CAPACITY (RATIO 1:20)	Lbs	75 ÷ 80

BASKET

Diameter	inches	47.3
Depth	inches	22.5
Volume	cu-ft	22.8
Wash speed	rpm	28
Extract speed	rpm	165 ÷ 340
Door opening	inches	20

SOLVENT TANKS

Useful volume tank 1	gal	63
Useful volume tank 2	gal	63
Useful volume tank 3	gal	87
FLOOR SAFETY TANK CAPACITY	gal	145

DESTILLATOR

Useful volume at half inspection	gal	95
Total volume	gal	120

ELECTRIC POWER (220 V - 60 Hz)

Wash motor	Hp	2.5	Kw	1.5
Extract motor	Hp	5.5 ÷ 7	Kw	4.15 ÷ 5.25
Solvent pump motor	Hp	1.5	Kw	1.1
Fan motor	Hp	5.5	Kw	4.15
Refrigerator compressor MT81	Hp	6.5	Kw	4.85
Nylon filter motor	Hp	2	Kw	1.5
Still residue pump	Hp	0.75	Kw	0.55
Exhaust fan motor	Hp	0.18	Kw	0.14
Fan motor Recuper	Hp	2	Kw	1.5

NOTE: Acoustic emission level of the machine is lower than 70 dB (A)

FILTRATION AVAILABLE IN THIS MODEL

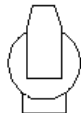
Version 03 - ONE NYLON FILTER			
	Volume nylon filter housing	gal	26,5
	Nylon filter area	ft ²	84
	Filter disks	nr	52

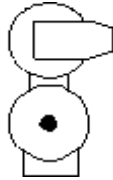
Version - 04 ONE NYLON FILTER AND ONE DECOLORATING FILTER KR			
	Volume nylon filter housing	gal	26,5
	Nylon filter area	ft ²	84
	Filter disks	nr	52
	KR Decolorating housing volume	gal	27,8
	KR Decolorating filter area	ft ²	112
	KR cartridges quantity	nr	4

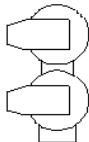
Version 05 - TWO NYLON FILTER			
	Volume nylon filter	gal	26,5 x 2 = 53
	Nylon filter area	ft ²	84 x 2 = 168
	Filter disks	nr	52 x 2 = 104



Version - 10 ONE NYLON ONE CARTRIDGE -KR ONE DECOLORATING PR			
	Volume nylon filter housing	gal	26,5
	Nylon filter area	ft ²	84
	Filter disks	nr	52
	KR Decolorating housing volume	gal	27,8
	KR Decolorating filter area	ft ²	28 x 4 = 112
	KR Decolorating cartridges	nr	4
	PR - Deco filter volume	gal	6,6
	Tubes	nr	1
	PR - Cartridge quantity	nr	2
	Decolorating carbon quantity	Lbs	8,8

Version 11 - TWO NYLON FILTER AND ONE DECO FILTER - PR			
	Volume nylon filter	gal	26,5 x 2 = 53
	Nylon filter area	ft ²	84 x 2 = 168
	Filter disks	nr	52 x 2 = 104
	PR - Deco filter volume	gal	6,6
	Tubes	nr	1
	PR - Cartridge quantity	nr	2
	Decolorating carbon quantity	Lbs	8,8

Version 14 - TWO NYLON FILTER AND TWO DECO FILTER - PR			
	Volume nylon filter	gal	26,5 x 2 = 53
	Nylon filter area	ft ²	84 x 2 = 168
	Filter disks	nr	52 x 2 = 104
	PR - Deco filter volume	gal	6,6 x 2 = 13,2
	Tubes	nr	2
	PR - Cartridge quantity	nr	4
	Decolorating carbon quantity	Lbs	17,6

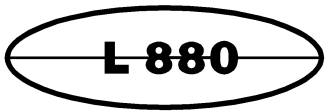

DIMENSIONS AND WEIGHTS - STANDARD VERSION

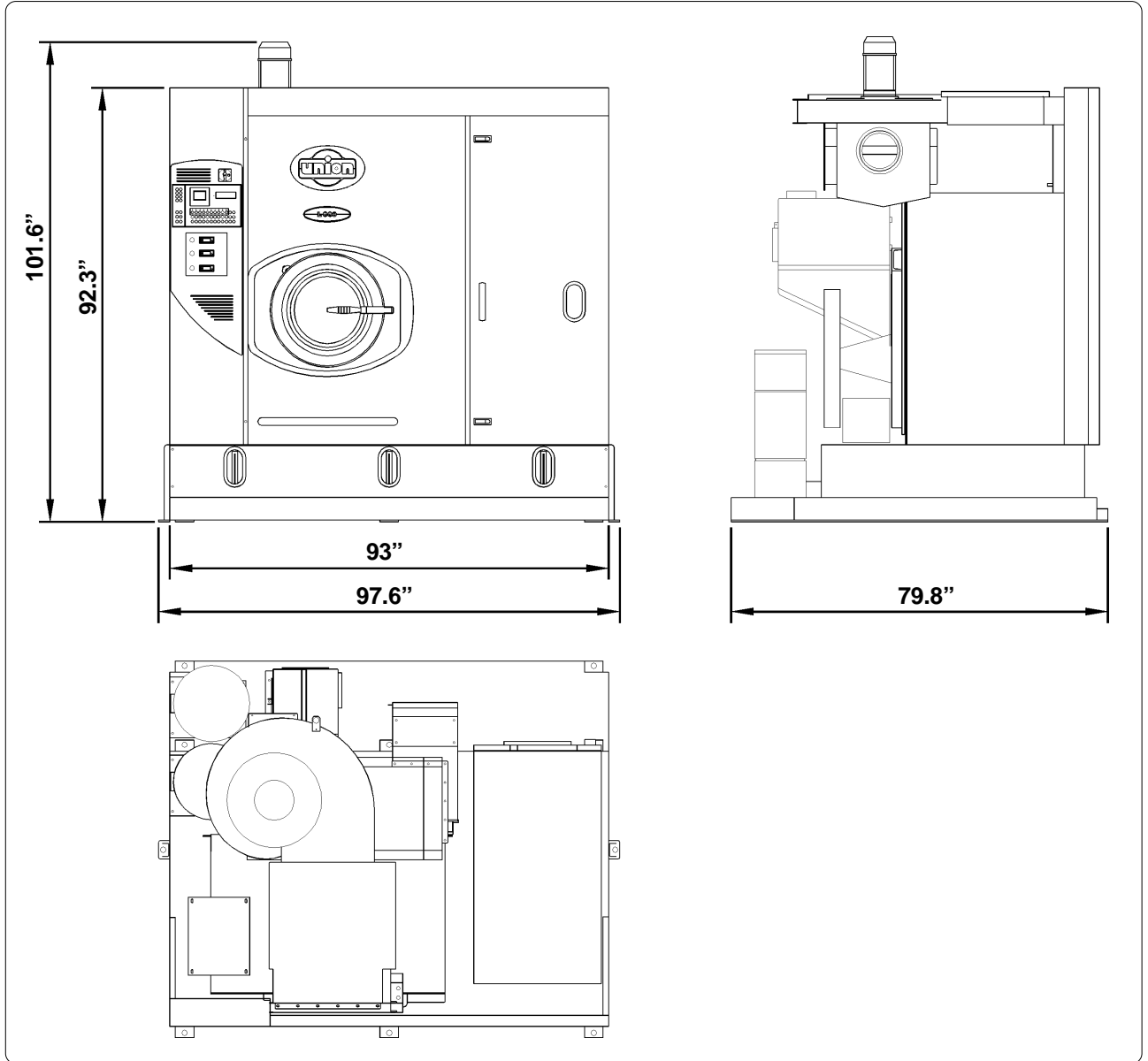

CHARGES		
Empty machine weight	Lbs	6051
Machine weight with solvent	Lbs	9788
Static charge on the floor with solvent	Lbs/ft ²	190
Dynamic charge on the floor (+10%)	Lbs/ft ²	246

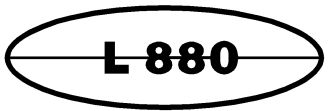

DIMENSIONS AND WEIGHTS - U2000 VERSION

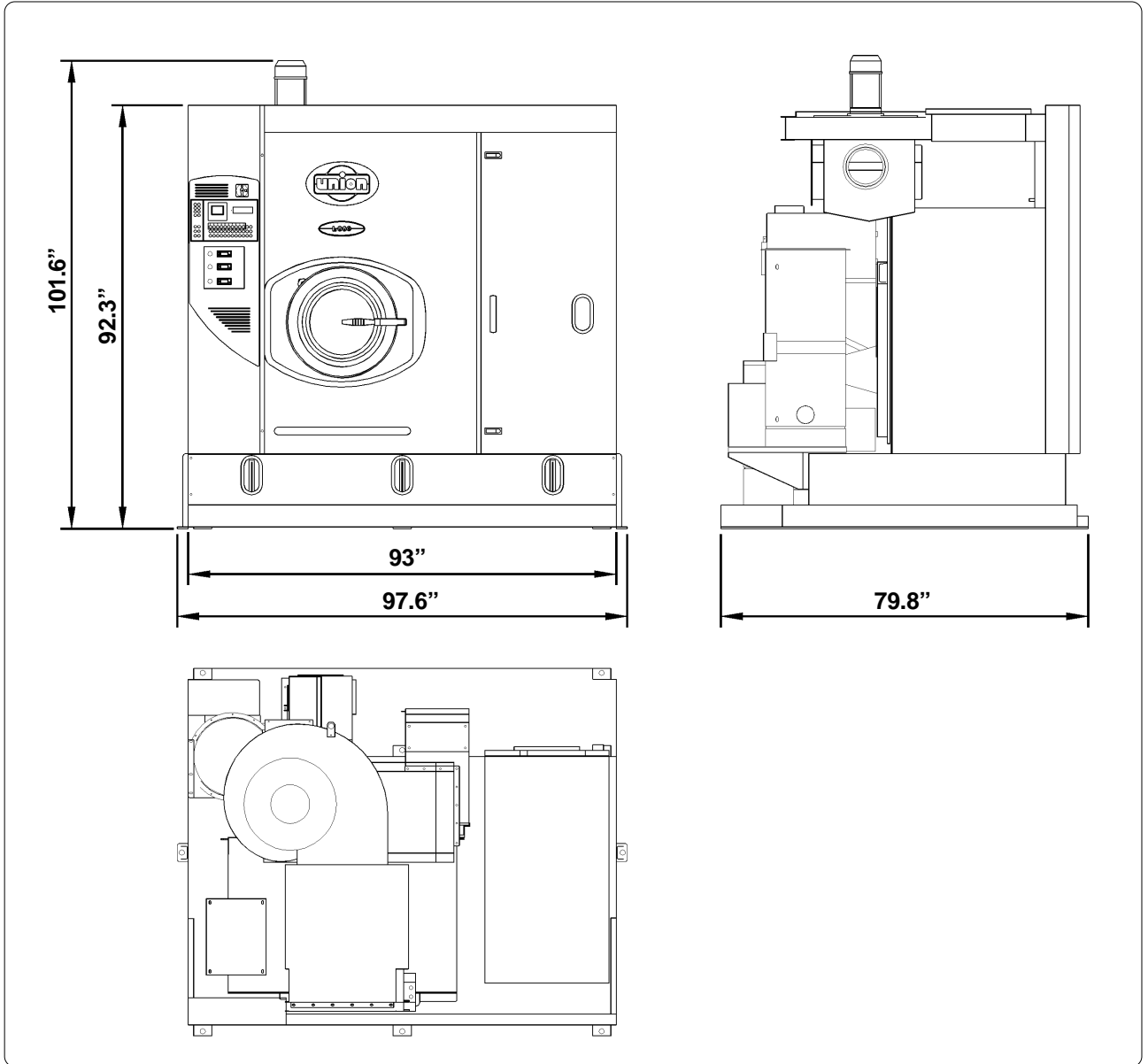

CHARGES		
Empty machine weight	Lbs	7020
Machine weight with solvent	Lbs	10758
Static charge on the floor with solvent	Lbs/ft ²	210
Dynamic charge on the floor (+10%)	Lbs/ft ²	266

PACKAGED MACHINE DIMENSIONS AND WEIGHTS

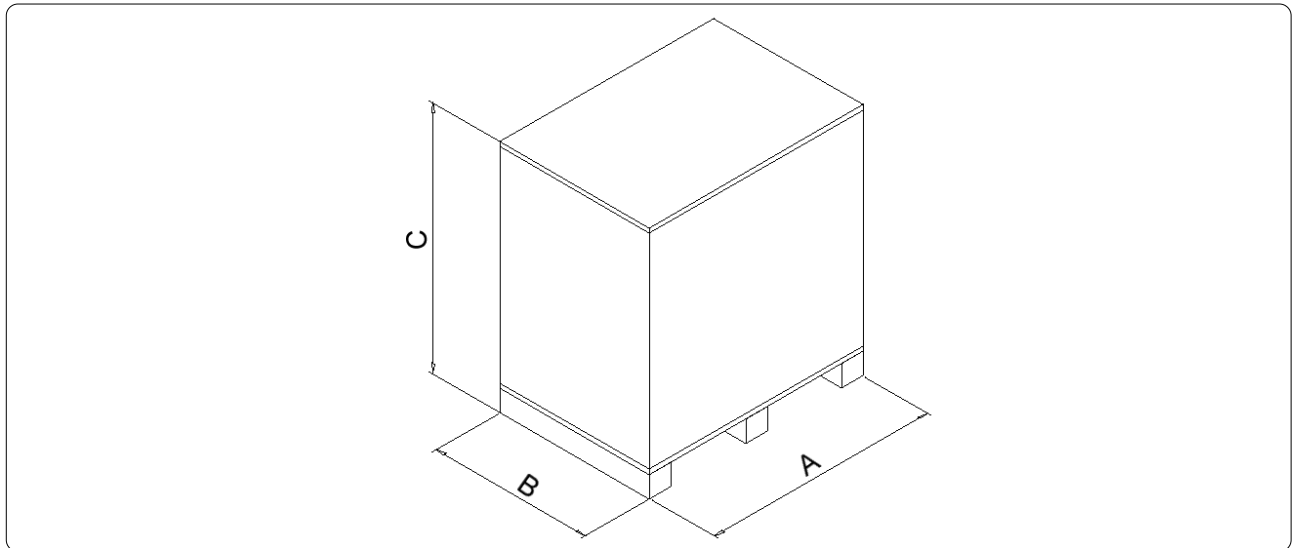

PACKAGED MACHINE DIMENSIONS			
Machine type		Wooden cage	Wooden case
L880	A	inches 107.5"	inches 88.2"
	B	inches 86.2"	inches 101.8"
	C	inches 97.2"	inches 99.6"
L880 U2000	A	inches 107.5"	inches 88.2"
	B	inches 86.2"	inches 101.8"
	C	inches 97.2"	inches 99.6"

PACKAGED MACHINE WEIGHTS		
Machine type	Wooden cage	Wooden case
L880	Lbs 6680	Lbs 7340
L880 U2000	Lbs 7658	Lbs 8310

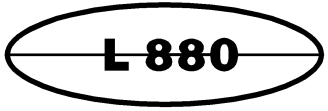

FIXING POINTS

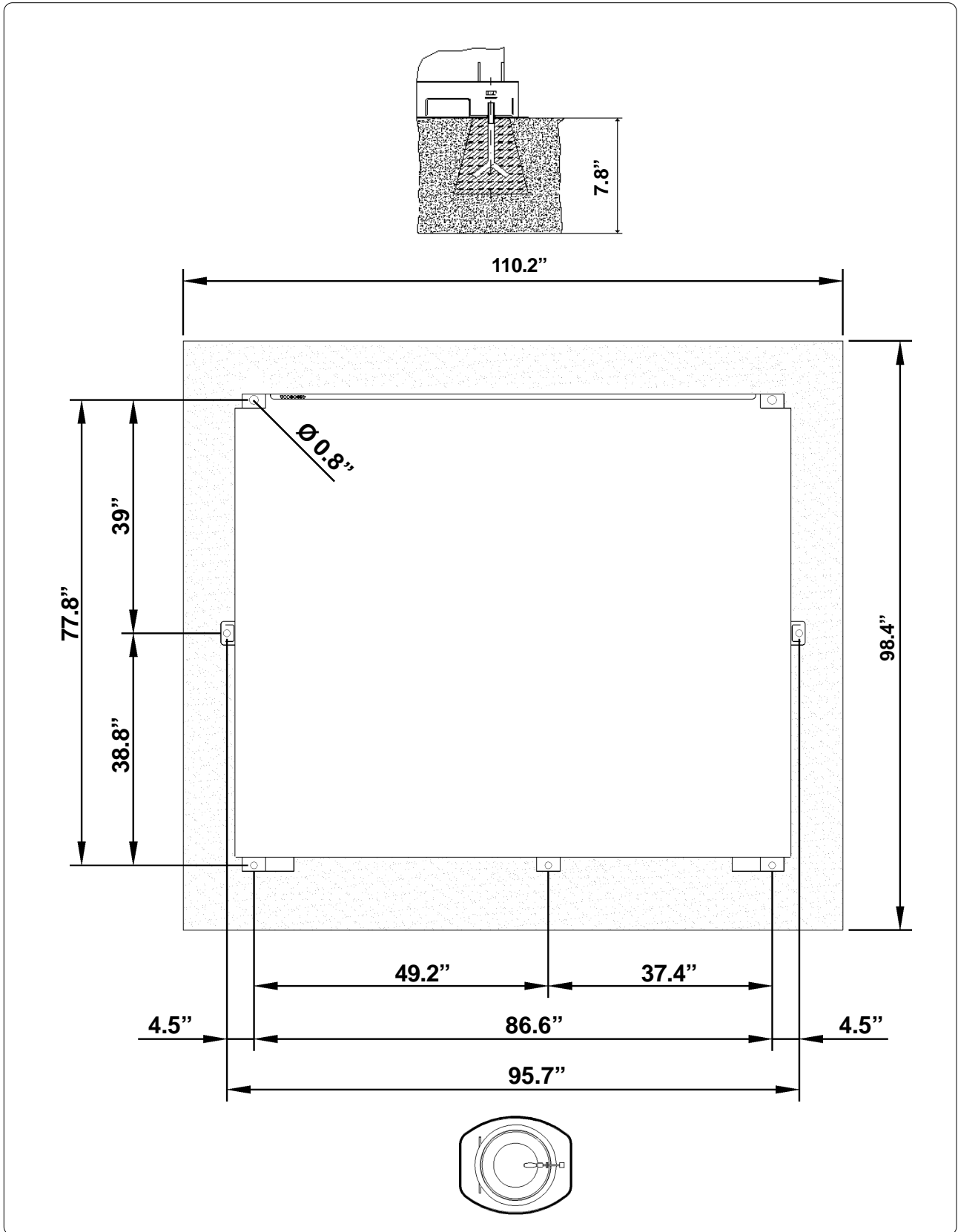

CONNECTIONS

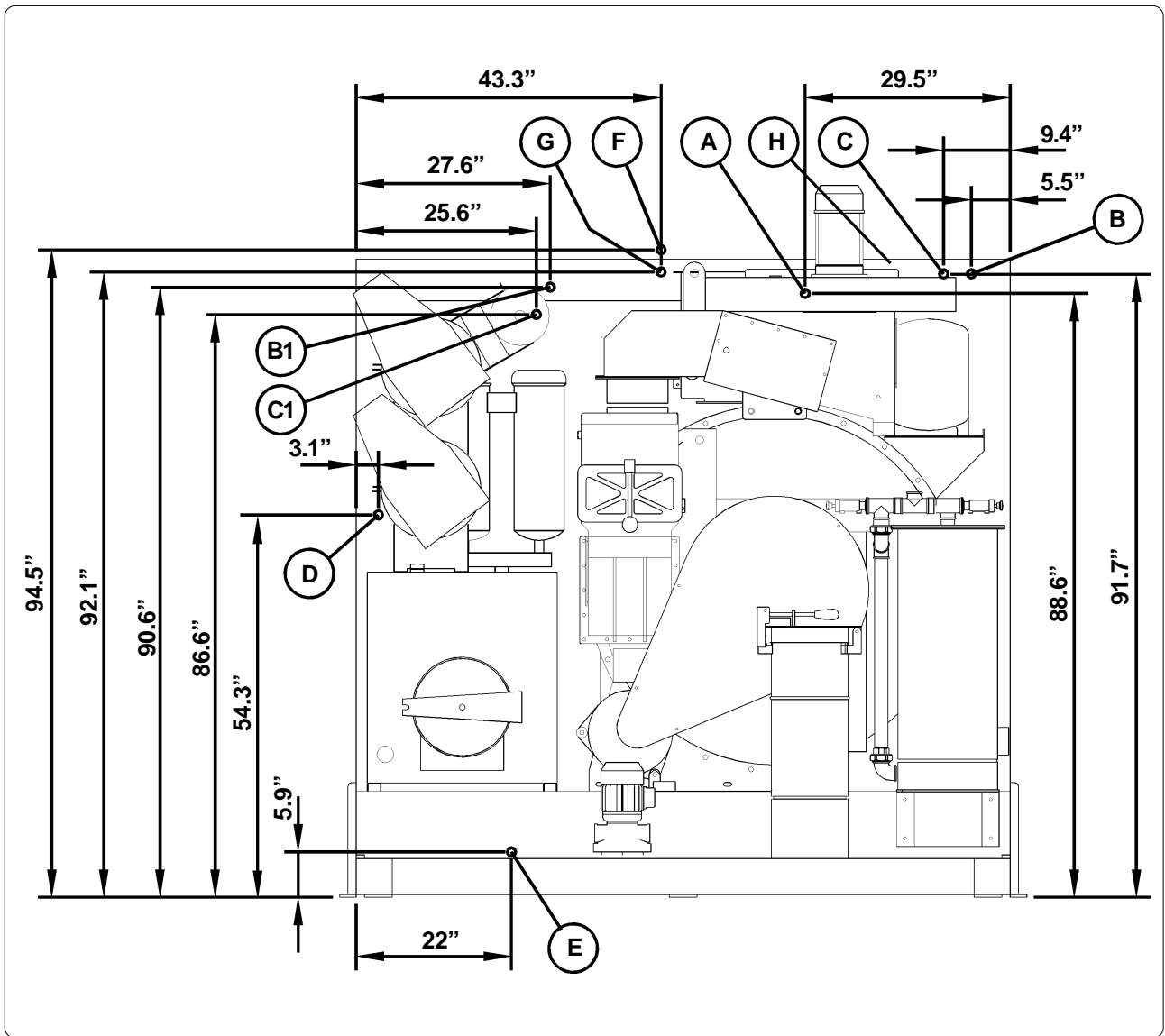

A	Compressed air inlet	mm 6
B - B1	Water inlet	Ø 1"- Ø 3/4"
C - C1	Water outlet	Ø 1"- Ø 3/4"
D	Steam still inlet	Ø 1/2"
E	Condensate still outlet	Ø 1/2"
F	Steam heater inlet	Ø 1/2"
G	Condensate heater outlet	Ø 1/2"
H	Electric connection	

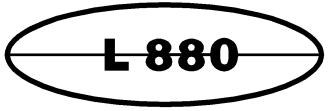

SOLVENT TYPE		PERCHLOROETHYLENE			
NECESSARY QUANTITY OF SOLVENT TO FILL THE MACHINE					
Machine Version - 03	gal	240	Lbs	3208	
Machine Version - 04	gal	268	Lbs	3583	
Machine Version - 05	gal	267	Lbs	3560	
Machine Version - 10	gal	275	Lbs	3670	
Machine Version - 11	gal	274	Lbs	3648	
Machine Version - 14	gal	280	Lbs	3737	

INFORMATION FOR THE ELECTRICAL CONNECTIONS (220 V - 60 Hz)				
STEAM Version	Kw	12	Amp	62

GENERAL INFORMATION		
Required water capacity	gal/min	3
Required water pressure	psi	40 ÷ 70
Required water temperature	°F	65° ÷ 70°
Required air pressure	psi	100 ÷ 115
Required steam pressure (Steam Version)	psi	55 ÷ 70
Required steam availability (Steam Version)	Lbs/h	132